



ENGINE

Make	FPT
Model	F4HFE613S
Emissions Certification	Tier 4 Final
Emissions Technology	SCR/DOC
Type	4-stroke, turbocharged and air-to-air cooled
Cylinders	6-cylinder in-line
Bore/Stroke	4.09 x 5.20 in (104 x 132 mm)
Displacement	411 in ³ (6.7 L)
Fuel	#2 Diesel, #1 and #2 mixture permitted for cold temperatures
Fuel injection	Direct injection – electronic
Fuel filter	Replaceable, spin-on cartridge
Fuel pump	Bosch CP 3.3
Gradeability:	
Side-to-side	35°
Fore and aft	35°
Air filter	Dry type elements w/ warning restriction indicator
Mid-mount cooling module w/ auto reversing fan:	
Mid-mount Air/Water w/ Lube Oil Cooler	
Fan – hydraulic driven:	
Style	8 blade puller
Diameter	32 in (813 mm)
Water pump	Integral
Engine oil pump operating angle ratings:	
Side-to-side	35°
Fore and aft	35°
Oil filtration	Replaceable, full flow spin-on cartridge
Engine speeds	RPM
Rated – full load	2000
Horsepower – Maximum Power:	
Peak gross @ 1800 RPM	230 hp (172 kW)
Net rated @ 2000 RPM	206 hp (153 kW)
Peak net @ 1800 RPM	213 hp (159 kW)
Torque – Maximum Power:	
Gross @ 1300 RPM	873 lb-ft (1 184 N-m)
Net @ 1300 RPM	845 lb-ft (1 145 N-m)
Net torque rise:	
Maximum power range	56%

NOTE: Gross horsepower and torque per SAE J1995.
Net horsepower and torque per SAE J1349.

DRIVETRAIN

Transmission:	4F/3R Proportional w/ Electronic Control Module torque sensing autoshift/manual shift and modulation	
Gears	Helical cut	
Gear ratios – 4-speed	Forward/Reverse	
1st	3.754/3.551	
2nd	2.184/2.071	
3rd	1.072/1.017	
4th	0.636/ —	
Gear ratios – 5-speed	Forward/Reverse	
1st	3.921/3.718	
2nd	2.255/2.138	
3rd	1.466/0.894	
4th	0.942/ —	
5th	0.613/ —	
Torque converter:		
Stall ratio – 4-speed	2.283:1	
Stall ratio – 5-speed	2.420:1	
Differential:	Limited slip w/ 67% available axle torque to wheel w/ traction	
Rear axle oscillation	24° total	
Front and rear axles:		
Differential ratio	4.11	
Planetary ratio	6.00	
Final axle ratio	24.67	
Heavy-duty axles – optional:		
Front axle equipped w/ locking differential		
Rear axle equipped w/ open differential		
Planetaries	Outboard	
Service brakes:	Hydraulically actuated, maintenance-free, multiple wet disc w/ accumulator to all four wheels	
Brake surface area:		
Rear hub	600 in ² (0.387 m ²)	
Front and opt. rear hub	721 in ² (0.465 m ²)	
Parking brakes:	Spring-applied hydraulic release disc on transmission output shaft neutralizes power flow to wheels when engaged	
Travel speeds – 4-speed transmission:		
	Forward	Reverse
	mph (kph)	mph (kph)
1st	4.4 (7.1)	4.7 (7.5)
2nd	7.4 (12.0)	7.8 (12.6)
3rd	14.5 (23.3)	15.2 (24.4)
4th	22.8 (36.6)	—
Travel speeds – 5-speed transmission:		
	Forward	Reverse
	mph (kph)	mph (kph)
1st	4.1 (6.6)	4.4 (7.0)
2nd	7.1 (11.4)	7.4 (12.0)
3rd	10.6 (17.1)	17.2 (27.7)
4th	16.4 (26.4)	—
5th	24.9 (40.0)	—

NOTE: Travel speeds at full engine throttle w/ 23.5-R25 L3 Radial tires.

ELECTRICAL

Voltage	24 Volts, negative ground
Alternator	120 amp
Batteries (2)	12-volt

OPERATOR ENVIRONMENT

ROPS cab AC w/ heat; 8" LCD touchscreen display, adjustable armrest w/ 3 configurable buttons; Key start; Articulated power steering w/ tilt column; Fully adjustable, suspension seat w/ headrest; Foot throttle; Single lever (joystick) loader control w/ auxiliary function and fully adjustable wrist rest, 2 cup holders; Interior rear view mirror; 3 inch (76 mm) retractable seat belt; Integrated 4-corner strobe; Multiple storage trays; Single brake pedal; F/N/R shuttle switch; Left and Right external rear view mirrors; Pressurized air filtering; Anti-glare window strip; Front and Rear Defroster; Side window, partial/fully open; 2 Dome lights; Wipers, rear and intermittent front; Windshield washers, front and rear; Rubber floor mat; Horn; Radio ready – Includes antenna, speakers, wiring, radio fuse, 20A converter, 12-volt auxiliary power outlet, and USB outlet.

Displays/Gauges:

Digital:

Transmission oil temperature; Engine coolant temperature; Fuel level; DEF level.

LCD screen:

Hour meter; Engine speed; Travel speed; Time; Automatic transmission indication; Current gear selection; FNR indication; DeClutch indication; Engine mode indication; Trip computer A/B; Fuel consumption; Multiple languages, Metric/English; Engine diagnostics; Transmission diagnostics; Warning prompts; Error reporting; Diff. Lock*.

Audible/Visual alarms:

Warning lights:

Four-way flashers and turn signals; Brake pressure; Lamp/high beam indication; Engine Block Heater.

Caution warnings:

Parking brake; Coolant temperature; Hydraulic oil temperature; Transmission oil temperature; Air filter; Transmission filter; Hydraulic filter; Alternator; Low fuel.

Critical warnings:

Engine oil pressure; Brake pressure; Steering pressure – w/ aux steering*; Coolant temperature; Hydraulic oil temperature; Transmission oil temperature.

Backup alarm

Maintenance reminders:

Cab air filter; Engine oil filter; Fuel pre-filter; DEF tank vent filter; SCR supply filter; Hydraulic oil and filter; Engine air filter; Engine coolant; Drive belt; Cab recirculation filter; Engine breather filter; Transmission breather; Front and rear axle fluid; SCR supply module filter.

NOTE: *If equipped w/ option.

OPERATING WEIGHT

Z-Bar

Unit equipped w/ 23.5-R25 L3 Radial tires; ROPS cab w/ heater and A/C; Heavy-duty counterweight – 4,940 lb (2 241 kg); Heavy-duty batteries; Front and rear fenders; Lights; Full fuel; 165 lb (75 kg) operator; 4.25 yd³ (3.2 m³) MD pin on w/ bolt on edge:

40,057 lb (18 170 kg)

XR

Unit equipped w/ 23.5-R25 L3 Radial tires; ROPS cab w/ heater and A/C; Heavy-duty counterweight – 4,940 lb (2 240 kg); Heavy-duty batteries; Front and rear fenders; Lights; Full fuel; 165 lb (75 kg) operator; 4.25 yd³ (3.2 m³) MD pin on w/ bolt on edge:

40,648 lb (18 438 kg)

HYDRAULICS

Main pump – steering/implement:

Closed center pressure/flow compensated

Tandem variable displacement – load-sensing:

Max rated flow x2: 31.6 gpm @ 2000 RPM
(120 L/min @ 2000 RPM)

Loader control valve:

Closed-center, sectional 2, 3 or 4-function w/ control for lift, tilt and auxiliary hydraulics

Loader auxiliary steering:

Hydraulic orbital center-pivot articulating w/ on-demand oil flow

High pressure standby:

Implement 3,625 psi (25 000 kPa)
Steering 3,500 psi (24 132 kPa)

Filtration:

Filtered vent w/ relief on hydraulic reservoir, maintains 3-5 psi on reservoir, 10-micron, return filter furnishes only clean oil to all components of the system

SERVICE CAPACITIES

Fuel tank 76.0 gal (288.0 L)

DEF tank – Diesel Exhaust Fluid:

Usable 9.8 gal (37.1 L)
Total 15.6 gal (58.9 L)

Hydraulic system:

Reservoir 24.0 gal (90.8 L)
Total 47.0 gal (178.0 L)

Transmission:

Service w/ filter 36.0 qt (34.1 L)

Front and rear axle:

Front axle 42.3 qt (40.0 L)
Rear axle 42.3 qt (40.0 L)

Engine oil w/ filter 16.0 qt (15.1 L)

Cooling system 32.0 qt (30.0 L)

OTHER SPECIFICATIONS

Lift cylinder:

Bore diameter 5.5 in (139.7 mm)
Rod diameter 3.0 in (76.2 mm)
Stroke 33.3 in (845.7 mm)

Dump cylinder:

Bore diameter 6.5 in (165.1 mm)
Rod diameter 3.5 in (88.9 mm)
Stroke 23.6 in (599.6 mm)

Loader:

Z-Bar loader linkage; Single control for lift and tilt; Positive hold float; Automatic return-to-dig; Automatic height control; Automatic return-to-travel; Brake pedal transmission disconnect; Bucket position indicator on bucket.

Cycle time:

Raise w/ rated bucket load 6.2 sec
Dump w/ rated bucket load 1.2 sec
Float down 2.5 sec

Sound level in Cab (LpA) 68 dB(A)

Exterior sound level (LwA) 104 dB(A)

NOTE: Sound level data tested in accordance with ISO6395, 6396, 3744.

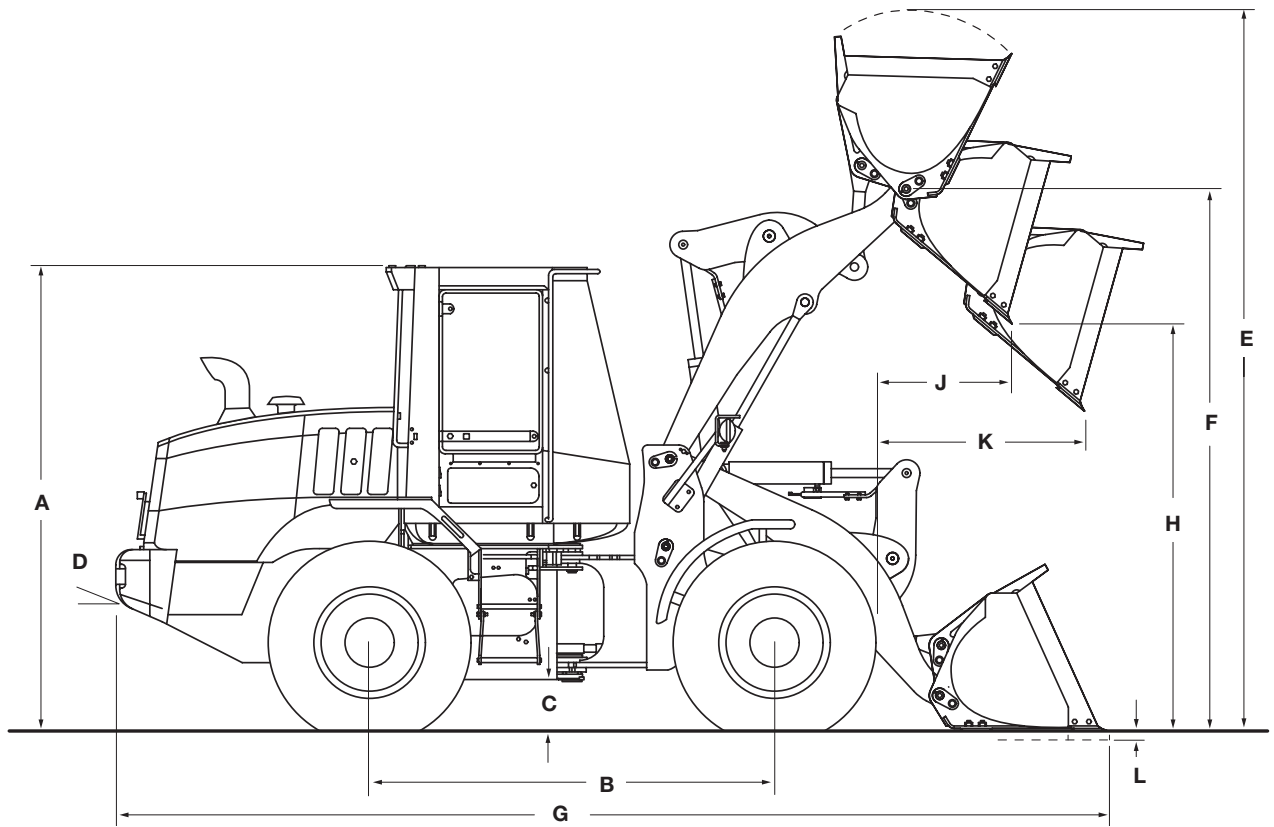

Line drawings are for illustrative purpose only and may not be exact representation of unit.

DIMENSIONS

A. Height to top of ROPS cab	136.2 in (3 460 mm)
Height to drawbar	42.6 in (1 081 mm)
B. Wheelbase	131.5 in (3 340 mm)
C. Ground clearance	17.0 in (431 mm)
D. Angle of departure	29°
Width:	
Overall* without bucket	111.4 in (2 829 mm)
Tread width	87.8 in (2 230 mm)
Turning radius* – outside	236.3 in (6 003 mm)
Turning angle:	
From center	40°
Total angle	80°
Rear axle oscillation – total	24°

NOTE: *Dimensions taken with 23.5-R25 L3 Radial tires. Additional dimensions on pages 4 through 8.

WEIGHT ADJUSTMENTS

Select Options	Weight Adjustment	Tipping Load Adjustment Straight: Deflected*	Tipping Load Adjustment 40° Turn: Deflected*
23.5-R25 L2 Bias	-748 lb (-339 kg)	-610 lb (-277 kg)	-971 lb (-440 kg)
23.5-R25 L2 Radial tires	-28 lb (-13 kg)	-104 lb (-47 kg)	-133 lb (-60 kg)
23.5-R25 Snow Radial Tires	+52 lb (+24 kg)	+162 lb (+73 kg)	+166 lb (+75 kg)

NOTE: Unit equipped with Z-Bar loader arms, 4.25 yd³ (3.2 m³) general purpose pin on bucket with bolt-on edge, 23.5-R25 L3 Radial tires, ROPS cab with heater and air conditioner, heavy counterweight, heavy-duty batteries, front and rear fenders, full fuel and 165 lb (75 kg) operator. Adjust select options from rated weight.
*Tipping loads: ISO 14397-1 Deflected Tires.

PERFORMANCE SPECS

821G Z-Bar*		4.5 yd³ (3.4 m³) Bucket with Bolt-on Edge - Pin On	4.25 yd³ (3.2 m³) Bucket with Bolt-on Edge - Pin On	4.0 yd³ (3.1 m³) Bucket with Teeth - Pin On
Operating weight		40,123 lb (18 200 kg)	40,057 lb (18 170 kg)	39,916 lb (18 106 kg)
E.	Operating height – fully raised with spillguard	216.7 in (5 505 mm)	215.4 in (5 471 mm)	215.4 in (5 471 mm)
F.	Hinge pin height – fully raised	162.2 in (4 120 mm)	162.2 in (4 120 mm)	162.2 in (4 120 mm)
G.	Overall length – bucket level on ground	316.5 in (8 039 mm)	315.1 in (8 004 mm)	321.0 in (8 153 mm)
Dump angle – fully raised		55°	55°	55°
H.	Dump height – fully raised, 45° dump	116.5 in (2 958 mm)	117.3 in (2 981 mm)	113.6 in (2 885 mm)
J.	Bucket reach – fully raised, 45° dump	44.4 in (1 128 mm)	43.4 in (1 102 mm)	47.8 in (1 215 mm)
K.	Bucket reach – 7 ft 0 in (2.13 m) height, 45° dump	67.4 in (1 712 mm)	66.8 in (1 696 mm)	69.4 in (1 762 mm)
L.	Dig depth	3.1 in (78 mm)	3.1 in (78 mm)	3.1 in (78 mm)
Operating load – ISO Rigid Tires		13,342 lb (6 052 kg)	13,409 lb (6 082 kg)	13,625 lb (6 180 kg)
Operating load – ISO Deflected Tires		12,189 lb (5 529 kg)	12,257 lb (5 560 kg)	12,457 lb (5 650 kg)
Maximum material density – ISO Rigid Tires		2,965 lb/yd ³ (1 759 kg/m ³)	3,155 lb/yd ³ (1 872 kg/m ³)	3,406 lb/yd ³ (2 021 kg/m ³)
Maximum material density – ISO Deflected Tires		2,709 lb/yd ³ (1 607 kg/m ³)	2,884 lb/yd ³ (1 711 kg/m ³)	3,114 lb/yd ³ (1 848 kg/m ³)
Tipping load – ISO Rigid Tires:				
	Straight	32,245 lb (14 626 kg)	32,384 lb (14 689 kg)	32,870 lb (14 910 kg)
	40° turn	26,684 lb (12 104 kg)	26,819 lb (12 165 kg)	27,249 lb (12 360 kg)
Tipping load – ISO Deflected Tires:				
	Straight	30,231 lb (13 713 kg)	30,375 lb (13 777 kg)	30,829 lb (13 984 kg)
	40° turn	24,377 lb (11 057 kg)	24,515 lb (11 120 kg)	24,913 lb (11 300 kg)
Lift capacity:				
	Full height	21,913 lb (9 939 kg)	21,980 lb (9 970 kg)	22,138 lb (10 042 kg)
	Ground	40,294 lb (18 277 kg)	40,434 lb (18 341 kg)	40,760 lb (18 488 kg)
Breakout force with tilt cylinder		34,301 lb (15 559 kg)	35,288 lb (16 007 kg)	37,922 lb (17 201 kg)
Loader clearance circle with bucket		524.0 in (13 311 mm)	523.3 in (13 291 mm)	526.5 in (13 373 mm)

821G XR		4.5 yd³ (3.4 m³) Bucket with Bolt-on Edge - Pin On	4.25 yd³ (3.2 m³) Bucket with Bolt-on Edge - Pin On	4.0 yd³ (3.1 m³) Bucket with Teeth - Pin On
Operating weight		40,714 lb (18 467 kg)	40,648 lb (18 438 kg)	40,507 lb (18 373 kg)
E.	Operating height – fully raised with spillguard	234.1 in (5 946 mm)	232.8 in (5 912 mm)	232.8 in (5 912 mm)
F.	Hinge pin height – fully raised	179.6 in (4 561 mm)	179.6 in (4 561 mm)	179.6 in (4 561 mm)
G.	Overall length – bucket level on ground	335.6 in (8 525 mm)	334.3 in (8 490 mm)	340.1 in (8 638 mm)
Dump angle – fully raised		49°	49°	49°
H.	Dump height – fully raised, 45° dump	133.8 in (3 399 mm)	134.7 in (3 422 mm)	130.9 in (3 326 mm)
J.	Bucket reach – fully raised, 45° dump	48.9 in (1 241 mm)	47.8 in (1 215 mm)	52.3 in (1 327 mm)
K.	Bucket reach – 7 ft 0 in (2.13 m) height, 45° dump	84.6 in (2 150 mm)	84.0 in (2 132 mm)	86.8 in (2 205 mm)
L.	Dig depth	5.7 in (145 mm)	5.7 in (145 mm)	5.7 in (145 mm)
Operating load – ISO Rigid Tires		10,620 lb (4 817 kg)	10,678 lb (4 843 kg)	10,850 lb (4 922 kg)
Operating load – ISO Deflected Tires		9,803 lb (4 446 kg)	9,861 lb (4,473 kg)	10,024 lb (4 547 kg)
Maximum material density – ISO Rigid Tires		2,360 lb/yd ³ (1 400 kg/m ³)	2,512 lb/yd ³ (1 491 kg/m ³)	2,713 lb/yd ³ (1 610 kg/m ³)
Maximum material density – ISO Deflected Tires		2,178 lb/yd ³ (1 293 kg/m ³)	2,320 lb/yd ³ (1 377 kg/m ³)	2,506 lb/yd ³ (1 487 kg/m ³)
Tipping load – ISO Rigid Tires:				
	Straight	25,750 lb (11 680 kg)	25,870 lb (11 735 kg)	26,253 lb (11 908 kg)
	40° turn	21,239 lb (9 634 kg)	21,355 lb (9 687 kg)	21,701 lb (9 843 kg)
Tipping load – ISO Deflected Tires:				
	Straight	24,386 lb (11 061 kg)	24,508 lb (11 117 kg)	24,874 lb (11 283 kg)
	40° turn	19,605 lb (8 893 kg)	19,723 lb (8 946 kg)	20,049 lb (9 094 kg)
Lift capacity:				
	Full height	20,079 lb (9 108 kg)	20,146 lb (9 138 kg)	20,302 lb (9 209 kg)
	Ground	30,646 lb (13 901 kg)	30,790 lb (13 966 kg)	31,106 lb (14 110 kg)
Breakout force with tilt cylinder		34,876 lb (15 820 kg)	35,879 lb (16 275 kg)	38,553 lb (17 488 kg)
Loader clearance circle with bucket		543.4 in (13 804 mm)	542.5 in (13 780 mm)	546.4 in (13 879 mm)

821G		Z-Bar/XR	Z-Bar/XR	Z-Bar/XR
Maximum rollback:				
	Ground	41°/37°	41°/37°	42°/37°
	Carry position	45°/43°	45°/43°	45°/43°
	@ Full height	59°/60°	59°/60°	59°/60°
Maximum grading angle with bucket – back dragging		60°/63°	60°/63°	61°/64°
SAE bucket capacity – struck		3.78 yd ³ (2.89 m ³)	3.63 yd ³ (2.78 m ³)	3.44 yd ³ (2.63 m ³)
Heaped		4.50 yd ³ (3.44 m ³)	4.25 yd ³ (3.25 m ³)	4.00 yd ³ (3.06 m ³)
Bucket width – outside		119.3 in (3 030 mm)	119.3 in (3 030 mm)	119.2 in (3 027 mm)
Bucket weight		3,464 lb (1 571 kg)	3,398 lb (1 541 kg)	3,256 lb (1 477 kg)

PERFORMANCE SPECS

821G Z-Bar*		4.0 yd³ (3.06 m³) Bucket with Bolt-on Edge - JRB Coupler	3.8 yd³ (2.9 m³) Bucket with Teeth - JRB Coupler	4.0 yd³ (3.1 m³) Bucket with Bolt-On Edge - ACS Coupler
Operating weight		41,430 lb (18 792 kg)	41,289 lb (18 728 kg)	41,483 lb (18 816 kg)
E.	Operating height – fully raised with spillguard	221.9 in (5 636 mm)	221.9 in (5 637 mm)	218.8 in (5 558 mm)
F.	Hinge pin height – fully raised	162.1 in (4 118 mm)	162.1 in (4 118 mm)	162.1 in (4 118 mm)
G.	Overall length – bucket level on ground	325.1 in (8 258 mm)	331.0 in (8 406 mm)	320.9 in (8 151 mm)
Dump angle – fully raised		55°	55°	55°
H.	Dump height – fully raised, 45° dump	110.9 in (2 817 mm)	107.1 in (2 721 mm)	113.6 in (2 886 mm)
J.	Bucket reach – fully raised, 45° dump	51.0 in (1 295 mm)	55.4 in (1 408 mm)	47.8 in (1 213 mm)
K.	Bucket reach – 7 ft 0 in (2.13 m) height, 45° dump	71.2 in (1 807 mm)	73.5 in (1 866 mm)	69.4 in (1 762 mm)
L.	Dig depth	3.1 in (79 mm)	3.2 in (80 mm)	3.1 in (79 mm)
Operating load – ISO Rigid Tires		11,830 lb (5 366 kg)	12,023 lb (5 454 kg)	12,170 lb (5 520 kg)
Operating load – ISO Deflected Tires		10,768 lb (4 884 kg)	10,947 lb (4 966 kg)	11,077 lb (5 024 kg)
Maximum material density – ISO Rigid Tires		2,958 lb/yd ³ (1 755 kg/m ³)	3,164 lb/yd ³ (1 877 kg/m ³)	3,042 lb/yd ³ (1 805 kg/m ³)
Maximum material density – ISO Deflected Tires		2,692 lb/yd ³ (1 597 kg/m ³)	2,881 lb/yd ³ (1 709 kg/m ³)	2,769 lb/yd ³ (1 643 kg/m ³)
Tipping load – ISO Rigid Tires:				
	Straight	28,844 lb (13 083 kg)	29,278 lb (13 280 kg)	29,661 lb (13 454 kg)
	40° turn	23,661 lb (10 732 kg)	24,046 lb (10 907 kg)	24,339 lb (11 040 kg)
Tipping load – ISO Deflected Tires:				
	Straight	27,004 lb (12 249 kg)	27,412 lb (12 434 kg)	27,762 lb (12 593 kg)
	40° turn	21,537 lb (9 769 kg)	21,894 lb (9 931 kg)	22,154 lb (10 049 kg)
Lift capacity:				
	Full height	20,513 lb (9 305 kg)	20,670 lb (9 376 kg)	20,500 lb (9 299 kg)
	Ground	28,363 lb (12 865 kg)	29,604 lb (13 428 kg)	32,373 lb (14 684 kg)
Breakout force with tilt cylinder		28,872 lb (13 096 kg)	30,698 lb (13 925 kg)	31,163 lb (14 135 kg)
Loader clearance circle with bucket		529.0 in (13 437 mm)	532.4 in (13 523 mm)	526.5 in (13 374 mm)

821G XR		4.0 yd³ (3.06 m³) Bucket with Bolt-on Edge - JRB Coupler	3.8 yd³ (2.9 m³) Bucket with Teeth - JRB Coupler	4.0 yd³ (3.1 m³) Bucket with Bolt-On Edge - ACS Coupler
Operating weight		42,021 lb (19 060 kg)	41,879 lb (18 996 kg)	42,074 lb (19 084 kg)
E.	Operating height – fully raised with spillguard	239.3 in (6 078 mm)	239.3 in (6 078 mm)	236.2 in (5 999 mm)
F.	Hinge pin height – fully raised	179.5 in (4 559 mm)	179.5 in (4 559 mm)	179.5 in (4 559 mm)
G.	Overall length – bucket level on ground	344.2 in (8 743 mm)	350.1 in (8 892 mm)	340.0 in (8 636 mm)
Dump angle – fully raised		49°	49°	49°
H.	Dump height – fully raised, 45° dump	128.3 in (3 258 mm)	124.5 in (3 162 mm)	131.0 in (3 327 mm)
J.	Bucket reach – fully raised, 45° dump	55.4 in (1 408 mm)	59.9 in (1 521 mm)	52.2 in (1 326 mm)
K.	Bucket reach – 7 ft 0 in (2.13 m) height, 45° dump	88.8 in (2 256 mm)	91.4 in (2 322 mm)	86.8 in (2 204 mm)
L.	Dig depth	5.8 in (146 mm)	5.8 in (147 mm)	5.8 in (146 mm)
Operating load – ISO Rigid Tires		9,382 lb (4 256 kg)	9,540 lb (4 327 kg)	9,613 lb (4 361 kg)
Operating load – ISO Deflected Tires		8,622 lb (3 911 kg)	8,771 lb (3 978 kg)	8,833 lb (4 007 kg)
Maximum material density – ISO Rigid Tires		2,346 lb/yd ³ (1 392 kg/m ³)	2,510 lb/yd ³ (1 490 kg/m ³)	2,403 lb/yd ³ (1 426 kg/m ³)
Maximum material density – ISO Deflected Tires		2,155 lb/yd ³ (1 279 kg/m ³)	2,308 lb/yd ³ (1 370 kg/m ³)	2,208 lb/yd ³ (1 310 kg/m ³)
Tipping load – ISO Rigid Tires:				
	Straight	23,007 lb (10 436 kg)	23,356 lb (10 594 kg)	23,569 lb (10 691 kg)
	40° turn	18,764 lb (8 511 kg)	19,079 lb (8 654 kg)	19,227 lb (8 721 kg)
Tipping load – ISO Deflected Tires:				
	Straight	21,745 lb (9 863 kg)	22,078 lb (10 015 kg)	22,272 lb (10 102 kg)
	40° turn	17,244 lb (7 822 kg)	17,541 lb (7 957 kg)	17,667 lb (8 013 kg)
Lift capacity:				
	Full height	18,692 lb (8 479 kg)	18,847 lb (8 549 kg)	18,674 lb (8 470 kg)
	Ground	28,087 lb (12 740 kg)	28,385 lb (12 875 kg)	28,592 lb (12 969 kg)
Breakout force with tilt cylinder		29,366 lb (13 320 kg)	31,221 lb (14 161 kg)	31,694 lb (14 376 kg)
Loader clearance circle with bucket		549.4 in (13 955 mm)	553.5 in (14 059 mm)	546.4 in (13 880 mm)

821G		Z-Bar/XR	Z-Bar/XR	Z-Bar/XR
Maximum rollback:	Ground	42°/37°	42°/37°	42°/37°
	Carry position	45°/43°	45°/43°	45°/43°
	@ Full height	59°/60°	59°/60°	59°/60°
Maximum grading angle with bucket – back dragging		62°/65°	64°/67°	61°/64°
SAE bucket capacity – struck		3.41 yd ³ (2.61 m ³)	3.25 yd ³ (2.48 m ³)	3.41 yd ³ (2.61 m ³)
Heaped		4.00 yd ³ (3.06 m ³)	3.80 yd ³ (2.91 m ³)	4.00 yd ³ (3.06 m ³)
Bucket width – outside		119.3 in (3 030 mm)	119.2 in (3 027 mm)	119.3 in (3 030 mm)
Bucket weight		4,770 lb (2 164 kg)	4,629 lb (2 100 kg)	4,824 lb (2 188 kg)

NOTE: *Z-Bar performance data shown with full counterweight.
Performance data unit equipped with 23.5-R25 L3 Radial tires, ROPS cab with heater and air conditioner, full counterweight, standard batteries, front and rear fenders, full fuel and 165 lb (75 kg) operator. Specifications per SAE J732, J1234, J695, J742, and J818.

STANDARD EQUIPMENT

OPERATOR ENVIRONMENT

See page 1

ENGINE

CASE/FPT F4HFE613S
Tier 4 Final Certified
Selective Catalytic Reduction (SCR) with Diesel Oxidation Catalyst
Selectable work modes:
Maximum Mode
Smart Mode
Turbocharger
Charge air cooling
Automatic belt tensioner
Integral engine oil cooling
Fuel filter with water trap
Dual-element dry-type air cleaner
Hydraulic-driven cooling fan
Air-cooled radiator
Mid-mounted cooling module with hydraulically driven auto reversing fan
Engine block heater
Common rail electronic fuel injection

LOADER

See page 2 – Operating weight,
Other specifications

DRIVETRAIN

4-wheel drive
4F/3R Selectable autoshift/manual shift transmission
Electronic Control Module – programmable, computer controlled proportional shifting with programmable gear selection
Onboard diagnostics
Single lever electronic shift control
F/N/R switch in loader control handle
Downshift button
Torque converter
Limited-slip differentials
Outboard planetary axles
Transmission oil cooler
Brake pedal transmission disconnect – declutch
Hydraulic wet disc brakes
Spring-applied hydraulic release parking brake
Limp-Home Mode
Greaseable rear axle trunnion
3-piece rims

HYDRAULICS

Adjustable Electro-hydraulic - EH loader control with one auxiliary function and 3 configurable buttons
Adjustable EH settings:
Smooth
Moderate
Aggressive
Auxiliary Hydraulics
Ride Control™
Locking hydraulics for coupler
EH Parallel Lift
Low-effort steering
Hydraulic driven cooling fan
Diagnostic quick couplers
Split flange hydraulic connections – 1 in or greater
Hydraulic oil cooler

ELECTRICAL

Alternator and voltage regulator
Battery isolator/electrical disconnect
120 amp alternator
(2) 700 CCA 12-volt batteries
Electric starter
Lights:
Integrated 4-corner strobe
2 Front and 2 rear halogen flood lights
2 Front driving headlights – high/low beam with integrated turn signals
2 LED stop/tail lights with integrated turn signals
Key start/stop switch
Backup alarm
Centrally located fuse box with all electrical circuits protected
Remote jump start posts

OTHER

Electric hood lift
Front and rear fenders, partial coverage
External rear view mirrors
Heavy counterweight
Drawbar hitch
Articulation locking bar
Lift arm locking bar
Lift and tie-down points – front/rear
Rear frame side covers
License plate brackets; front bracket and lit rear bracket
Rubber steering stops
Grouped remote-mounted ecology drains:
Engine oil
Engine coolant
Hydraulic oil

TELEMATICS

CASE SiteWatch™ Telematics – includes hardware and a 3-yr Advanced data subscription
SiteConnect Module providing remote diagnostics capability

OPTIONAL EQUIPMENT

OPERATOR ENVIRONMENT

Cloth-covered heated air-suspension seat with headrest
Sound Shield noise suppression package
Bluetooth radio, 12V AM/FM with auxiliary input
Cab convenience package:
Rear sun shade, interior mirror, under the seat drawer, coat hook, 12V accessory port, and an ash tray
In cab powered cooler box
In cab accessory mount
Rear view camera
External heated rear view mirrors
Front LED driving/headlights
LED front and rear work lights – 4 front, 2 rear

DRIVETRAIN

5F/3R Autoshift/manual shift transmission, lockup torque converter, PowerInch de-clutch
Heavy-duty axles:
With locking front differential and open/conventional rear differential
Cold weather package:
Heavy-duty (2) 950 CCA 12V batteries
Fuel heater
Hydraulic oil cooler bypass
Low temperature hydraulic oil
Fast-warm hydraulic valve

HYDRAULICS

Secondary steering
Integrated Payload System
Tire Pressure Monitoring System
2-function loader valve with joystick loader control
4-function loader valve with joystick loader control and two proportional auxiliary roller switches

LOADER

XR extended reach version
Attachment auxiliary hydraulics
Coupler systems – JRB or ACS compatible
Buckets – see pages 4 through 6

TIRES

23.5 x 25 L2 bias – dirt/traction
23.5 x 25 L3 bias – rock
23.5-R25 L2 radial – dirt/traction
23.5-R25 L3 radial – rock
23.5-R25 radial Michelin SnoPlus
Axle oscillation stops

ADVANCED ENGINE AIR FILTRATION

Sy-Klone® ejector type pre-cleaner

OTHER

Additional RH steps and platform with standard or wide fenders
12.4 mph (20 kph) maximum speed control
Special paint
Skid plate and transmission
Standard fenders with right and left hand steps
Wide full coverage fenders with right and left hand steps

CaseCE.com

©2021 CNH Industrial America LLC. All rights reserved. CASE is a trademark registered in the United States and many other countries, owned by or licensed to CNH Industrial N.V., its subsidiaries or affiliates. CNH Industrial Capital is a trademark in the United States and many other countries, owned by or licensed to CNH Industrial N.V., its subsidiaries or affiliates. Printed in U.S.A. Contains 10% post-consumer fiber.

IMPORTANT: CASE Construction Equipment Inc. reserves the right to change these specifications without notice and without incurring any obligation relating to such change. Availability of some models and equipment builds vary according to the country in which the equipment is used. The illustrations and text may include optional equipment and accessories and may not include all standard equipment. Your CASE dealer/distributor will be able to give you details of the products and their specifications available in your area.



CASE Construction Equipment is biodiesel-friendly. NOTE: All engines meet current EPA emissions regulations. All specifications are stated in accordance with SAE Standards or Recommended Practices, where applicable.



Always read the Operator's Manual before operating any equipment. Inspect equipment before using it, and be sure it is operating properly. Follow the product safety signs and use any safety features provided.

Form No. CCE202104821G
Replaces Form No. CCE201910821G

821G

7 of 7