



ENGINE

Model	FPT F5HFL463A*W
Emissions Certification	Tier 4B Final
Type	Diesel 4-stroke, Turbocharged
Cylinders	4
Bore/Stroke	3.90 x 4.33 in (99 x 110 mm)
Displacement	207 in ³ (3.4 L)
Fuel injection	Direct, high pressure common rail – HPCR
Fuel	Diesel
Engine speeds*	RPM
Rated speed – full load	2200
Low idle	900 – 1000
High idle – no load	2330 – 2430
Horsepower @ 2200 RPM:	
Gross	74 hp (55 kW)
Net w/ viscous fan**	72 hp (54 kW)
Net	68 hp (51 kW)
Maximum torque @ 1400 RPM:	
Gross	233 lb-ft (316 N-m)
Net w/ viscous fan	228 lb-ft (310 N-m)
Net	220 lb-ft (298 N-m)
Torque rise at rated speed	35% +/- 5%
Radiator:	
Core type	Square wave
Core size area	490.3 in ² (3 163 cm ²)
Rows of tubes	4

NOTE: *Meets federal emission regulations.

**Viscous fan available as DIA
w/ High Ambient Kit.

DRIVETRAIN

Transmission – standard:
4F-4R Power Shuttle Synchronesh Transmission
manual gear shift, fully synchronized

Gear ratios	Forward/Reverse
1st	5.603/4.643
2nd	3.481/2.884
3rd	1.585/1.313
4th	0.793/0.657

Travel speeds – Standard Power Shuttle

Transmission	Forward Reverse	
	mph (kph)	mph (kph)
1st	3.5 (5.7)	4.3 (7.0)
2nd	5.7 (9.1)	6.9 (11.2)
3rd	12.1 (19.5)	14.8 (23.8)
4th	21.1 (34.0)	–

Torque converter ratio 3.0

Front/Rear axle:	
Differential ratio	2.29/2.47
Planetary hub ratio	6.0/6.9
Total reduction ratio	13.7/17.0

Service brakes:
Hydraulic foot operated 2 per side.
Total disc area 228 in² (0.15 m²)

Parking brakes Trans Mounted
Mechanically actuated caliper type brake
pack on rear axle input shaft

NOTE: Travel speeds at 2200 engine
RPM specified: w/ 16.9-28 tires.
Speeds decrease w/ 14.0-25 rear tires.

ELECTRICAL

Voltage	12 Volts, negative ground
Alternator	120 amp
Battery	800 cold-cranking amps
Power plugs	10 amps total

OPERATOR ENVIRONMENT

ROPS/FOPS certified protective canopy;
Rear fenders extensions; Interior rearview convex
mirror; Mechanical suspension seat – 180° swivel
– Vinyl; 2 in (51 mm) retractable seat belt.

Gauges:
Engine coolant temperature; Converter oil
temperature; Fuel level; Tachometer/
hourmeter; Voltmeter.

Warning lights:
Air cleaner restriction; A/C Low or High
Pressure; Cold start; Engine oil pressure;
Hydraulic oil filter bypass; Parking brake
engagement; Low fuel; Water in fuel; Battery
Charging; Transmission Oil Temperature; Brake
Oil Level; High Coolant Temperature; Master
Warning; Master Stop.

Audible alarms:
Coolant temperature; Engine oil pressure;
Parking brake engagement; Backup alarm;
Cold Start; Transmission Oil Temperature; Brake
Oil Level; Hydraulic oil filter bypass.

Horn Dual switched front and rear

OPERATING WEIGHT

Operating Weight 18,298 lb (8 300 kg)

HYDRAULICS

Pump:

Parker Twin Section Gear Pump	
Flow Ratings	32.5 gpm @ 2200 RPM (123 L/min @ 152 bar)

Main relief pressure:

Standard	3,045 +/- 72.5 psi (210 +/- 5 bar)
----------	---------------------------------------

Filtration:

10 micron, return line, full flow, spin on element.

Oil cooler

Heavy-duty

Loader control valve:

Two or three spool sectional valve. The two spool valve has single lever control for lift and tilt. The three spool valve has two lever control of which first lever is for lift and tilt and second lever is for clam and tilt. The lift lever has positive hold "float" position.

Maximum backhoe flow for 1-way

auxiliary hydraulics	42 gpm @ 3,045 psi (160 L/min @ 210 bar)
----------------------	---

Backhoe control valve:

Six-spool monoblock open center control valve w/ optional seventh spool.

Basic control valve has an open center parallel circuit for all functions.

1-way flow auxiliary hydraulics:

1-way flow hydraulic valve is equipped w/ an adjustable LS relief valve to control attachment pressure and a 6 position flow control selector for 6 detented, distinct flow settings.

Actuation:

Manual backhoe controls – cab floor pedal

SERVICE CAPACITIES

Fuel tank	34 gal (129 L)
Hydraulic system:	
Total	113 qt (107 L)
Reservoir w/ filter	58 qt (55.0 L)
Reservoir w/o filter	56 qt (53.0 L)
Transmission – total system:	
4WD Standard	21 qt (20 L)

Front axle:

4WD Differential	9.3 qt (8.9 L)
4WD Planetaries – each	0.7 qt (0.7 L)

Rear axle:

Differential and planetaries	15.2 qt (14.5 L)
------------------------------	------------------

Window washer reservoir

1.5 qt (1.4 L)

OTHER SPECIFICATIONS

Front tires:

4WD	16.9-28 12-ply rating
-----	-----------------------

Rear tires:

4WD	12.5/80 - 18 12-ply rating
-----	----------------------------

Turning radius: Curb to Curb:

4WD – engaged:

Brakes on	11 ft 4 in (3.45 m)
Brakes off	13 ft 10 in (4.21 m)

LOADER BUCKET SIZES

Type	Width	Weight	Capacity
Standard Bucket without bolt-on edge	89 in (2.28 m)	1,014 lb (460 kg)	1.20 yd ³ (0.92 m ³)
4 IN 1 [®] Bucket with bolt-on edge	89 in (2.30 m)	1,235 lb* (560 kg)	1.00 yd ³ (0.76 m ³)

NOTE: *Weight of 4 IN 1[®] bucket only.

BACKHOE BUCKET SIZES

Type	Width	Weight	Heaped Capacity
Heavy Duty Buckets	12 in (305 mm)	295 lb (134 kg)	3.40 ft ³ (0.10 m ³)
	18 in (457 mm)	232 lb (105 kg)	4.70 ft ³ (0.13 m ³)
	24 in (610 mm)	272 lb (123 kg)	6.26 ft ³ (0.18 m ³)
Universal Buckets	30 in (762 mm)	489 lb (222 kg)	10.20 ft ³ (0.29 m ³)
	36 in (914 mm)	552 lb (251 kg)	12.70 ft ³ (0.36 m ³)

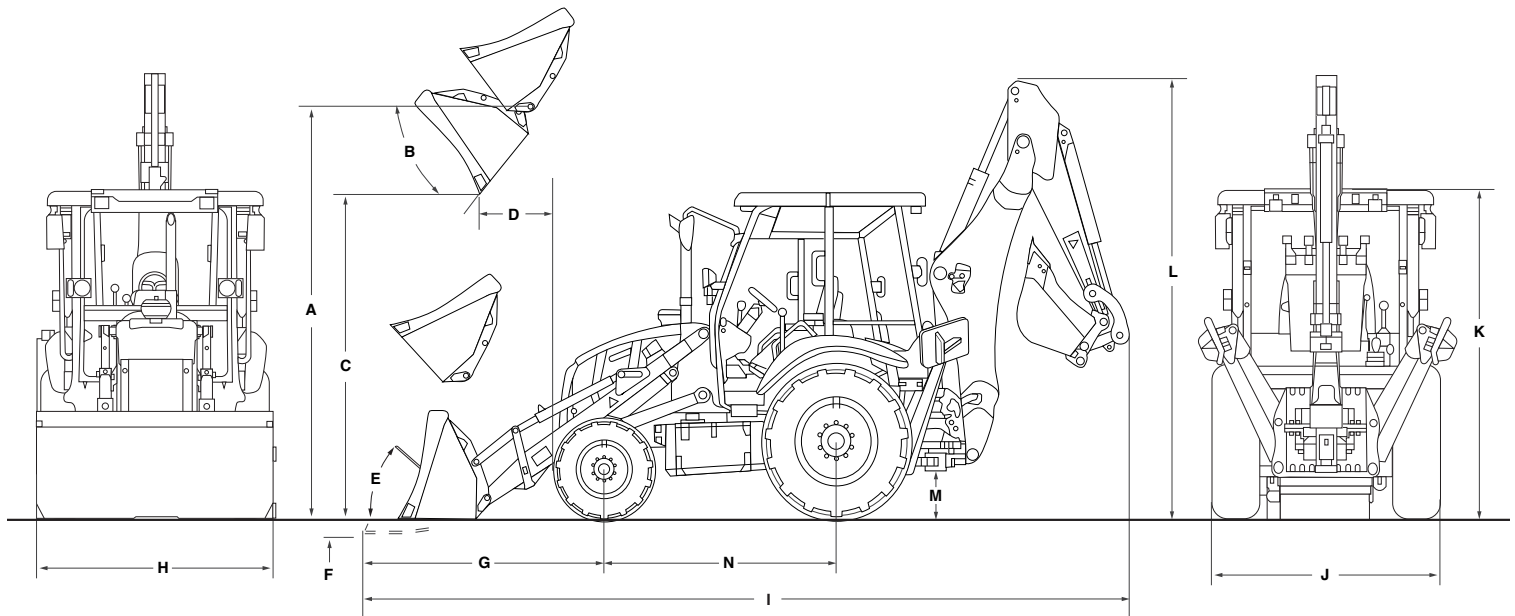

Line drawings are for illustrative purpose only and may not be exact representation of unit.

LOADER DIMENSIONS

	Standard Bucket
Height to:	
A. Bucket hinge pin fully raised	11 ft 9 in (3.58 m)
B. Dump angle at full height	45°
C. Dump clearance at full height, 45° dump: Bucket	9 ft 0 in (2.73 m)
D. Dump reach at full height, 45° dump – from bumper: Bucket	3 ft 9 in (1.15 m)
Bucket rollback:	
E. @ Groundline	33°
F. Digging depth below grade: Bucket flat	4.3 in (110 mm)
G. Reach from front axle centerline – bucket on ground	6 ft 6 in (1.98 m)
Lift capacity to full height	8,157 lb (3 700 kg)
Breakout force:	
Lift cylinders	11,277 lb (5 115 kgf)
Dump cylinders	13,788 lb (6 250 kgf)
H. Bucket cutting edge width	89.6 in (2.27 m)
Raising time to full height	5.9 sec
Bucket dumping time	1.8 sec
I. Overall transport length with standard loader bucket	23 ft 1 in (7.03 m)
J. Overall machine width with standard loader bucket	7 ft 6 in (2.28 m)
Stabilizer width – in raised position	7 ft 7 in (2.30 m)
Height:	
K. To top of cab	9 ft 3 in (2.83 m)
L. Overall transport height	12 ft 7 in (3.84 m)
M. Ground clearance at backhoe frame	19.7 in (500 mm)
N. Wheelbase	85.6 in (2.18 m)

NOTE: Loader dimensions taken with 4WD, 12.5-18 front tires and 16.9-28 rear tires.

CYLINDERS

	Bore Diameter	Rod Diameter	Stroke	Closed Length
Loader:				
Lift – 2	3.54 in (90 mm)	1.97 in (50 mm)	28.62 in (727 mm)	40.94 in (1 040 mm)
Dump – 2	3.15 in (80 mm)	1.57 in (40 mm)	26.97 in (685 mm)	36.42 in (925 mm)
4 IN 1® clam – 2	3.15 in (80 mm)	1.97 in (50 mm)	9.65 in (245 mm)	18.39 in (467 mm)
Backhoe:				
Boom	5.12 in (130 mm)	2.56 in (65 mm)	35.71 in (907 mm)	47.52 in (1 207 mm)
Dipperstick	4.92 in (125 mm)	2.56 in (65 mm)	27.36 in (695 mm)	39.72 in (1 009 mm)
Bucket	3.54 in (90 mm)	2.56 in (65 mm)	30.00 in (762 mm)	42.24 in (1 073 mm)
Extendahoe®	2.95 in (75 mm)	1.77 in (45 mm)	41.34 in (1 050 mm)	55.12 in (1 400 mm)
Swing – 2	4.33 in (110 mm)	2.36 in (60 mm)	9.37 in (238 mm)	5.35 in (136 mm)
Stabilizer – 2	3.94 in (100 mm)	2.36 in (60 mm)	24.80 in (630 mm)	37.01 in (940 mm)

AXLE RATINGS

	Rear	Front
Maximum static	58,264 lb (26 429 kg)	61,146 lb (27 735 kg)
Dynamic operating	39,368 lb (17 857 kg)	37,283 lb (16 911 kg)
Static operating	15,747 lb (7 143 kg)	14,913 lb (6 764 kg)

BACKHOE LIFT CAPACITIES

Standard Backhoe		Extendahoe®	
Boom Lift	Lift Capacity lb (kg)	Retracted Lift Capacity lb (kg)	Extended Lift Capacity lb (kg)
+16 ft (4.87 m)	—	—	2,512 (838)
+14 ft (4.27 m)	4,024 (1 829)	3,516 (1 598)	2,583 (1 142)
+12 ft (3.66 m)	4,138 (1 881)	3,597 (1 635)	2,594 (1 174)
+10 ft (3.05 m)	4,070 (1 850)	3,540 (1 609)	2,572 (1 179)
+8 ft (2.44 m)	3,953 (1 797)	3,423 (1 556)	2,537 (1 169)
+6 ft (1.83 m)	3,815 (1 734)	3,309 (1 504)	2,490 (1 153)
+4 ft (1.22 m)	3,689 (1 677)	3,192 (1 451)	2,455 (1 132)
+2 ft (0.61 m)	3,573 (1 624)	3,078 (1 399)	2,455 (1 116)
Ground Level	3,469 (1 577)	2,985 (1 357)	2,409 (1 095)
-2 ft (0.61 m)	3,366 (1 530)	2,893 (1 315)	2,374 (1 079)
-4 ft (1.22 m)	3,298 (1 499)	2,814 (1 279)	2,352 (1 069)
-6 ft (1.83 m)	3,238 (1 472)	2,754 (1 252)	2,328 (1 058)
-8 ft (2.44 m)	3,227 (1 467)	2,732 (1 242)	2,328 (1 058)
-10 ft (3.05 m)	3,344 (1 520)	2,801 (1 273)	2,363 (1 074)
-12 ft (3.66 m)	—	—	2,466 (1 121)
-14 ft (4.27 m)	—	—	2,860 (1 300)
Dipper Lift			
+14 ft (4.27 m)	—	—	3,612 (1 642)
+12 ft (3.66 m)	5,544 (2 520)	4,948 (2 249)	3,936 (1 789)
+10 ft (3.05 m)	5,331 (2 423)	5,819 (2 645)	3,876 (1 762)
+8 ft (2.44 m)	5,438 (2 472)	5,819 (2 645)	3,923 (1 783)
+6 ft (1.83 m)	5,962 (2 710)	5,819 (2 645)	4,101 (1 864)
+4 ft (1.22 m)	—	5,819 (2 645)	4,495 (2 043)
+2 ft (0.61 m)	—	—	5,390 (2 450)

BACKHOE OPERATIONAL DATA*

	Standard Backhoe	Extendahoe®	
		Retracted	Extended
Digging depth:			
Maximum	14 ft 5 in (4.40 m)	14 ft 11 in (4.55 m)	18 ft 4 in (5.58 m)
2 ft (610 mm) flat bottom	14 ft 3 in (4.34 m)	14 ft 11 in (4.55 m)	18 ft 4 in (5.58 m)
8 ft (2.44 m) flat bottom	13 ft 1 in (3.99 m)	13 ft 9 in (4.19 m)	17 ft 5 in (5.30 m)
Overall reach from swing pivot	18 ft 7 in (2.66 m)	19 ft 0 in (5.79 m)	22 ft 1 in (6.74 m)
Loading height	11 ft 11 in (3.64 m)	12 ft 4 in (3.75 m)	14 ft 5 in (4.39 m)
Loading reach with bucket closed	6 ft 5 in (1.96 m)	6 ft 9 in (2.05 m)	9 ft 6 in (2.89 m)
Swing arc	180°	180°	180°
Bucket rotation:			
Using Bucket Economy Hole	204°	204°	204°
Using Bucket Power Hole	160°	160°	160°
Stabilizer spread	10 ft 7 in (3.23 m)	10 ft 7 in (3.23 m)	10 ft 7 in (3.23 m)
Digging force:			
Bucket cylinder	12,359 lb (5 606 kg)	12,381 lb (5 616 kg)	12,381 lb (5 616 kg)
Dipper cylinder	9,449 lb (4 286 kg)	8,885 lb (4 030 kg)	6,462 lb (2 931 kg)

STANDARD EQUIPMENT

OPERATOR ENVIRONMENT

See page 1

ENGINE

FPT F5 diesel
Full flow engine oil filter
Aspirated air cleaner – replaceable dual element dry type with radial seal
Fuel filter with water trap
Diesel Oxidation Catalyst (DOC) – Spark Arresting
Radiator with de-aeration bottle
Antifreeze to -34° F (-37° C)
Throttles, both hand rotary and foot
Self adjusting belt
High Pressure Common Rail

DRIVETRAIN

Front axle:
4WD mechanically driven front axle, with 12.5/80-18 tires
Rear axle:
4WD heavy-duty outboard planetary drive, with 16.9-28 tires
4F-4R Power Shuttle
Synchromesh transmission
Torque converter – 11.8 in (300 mm)
On-the-go electric 4WD control
Electric F/R shuttle control
No differential lock

HYDRAULICS

Heavy-duty hydraulic oil cooler
10-micron, spin on oil filter

BACKHOE

Center pivot design
1-way Auxiliary backhoe hydraulics for hammers, plate compactors or similar
1-way flow attachments - pedal switch activated
2-lever mechanical backhoe controls
Flip over stabilizer pads

OTHER

Forward tilt engine hood
Replaceable, molded front bumpers
Front/Rear tie downs
Reflective logos
Working/Driving/Signal Lights – halogen
Master disconnect switch and remote jump-start terminals
Backup alarm
Vertical spin-on engine oil, fuel and hydraulic filters

WARRANTY

1-Year/Unlimited-Hour Full-Coverage Base Limited Warranty
2-Year/2,000-Hour Extended Engine Warranty

OPTIONAL EQUIPMENT

OPERATOR ENVIRONMENT

ROPS/FOPS certified protective cab
2 Door with heat, A/C, defroster, door activated dome light, 4 front and 4 rear lights, floor mat, tinted glass, radio ready, front and rear wiper and front fenders
Mechanical suspension seat with flip-up armrests, 180° swivel, adjustable seat and weight, backrest angle, lumbar and cushion angle – cab units cloth or vinyl, canopy units vinyl only

LOADER

3-spool auxiliary hydraulics valve for loader mounted equipment - 2-lever loader control
Buckets – see page 2

BACKHOE

Pilot Backhoe Controls
Extendahoe®
Buckets – see page 2

OTHER

Front Fenders

SERVICE PARTS

Bluetooth Radio
3 inch seat belt
CASE SiteWatch™ Telematics
Rotating Beacon

CaseCE.com

©2022 CNH Industrial America LLC. All rights reserved. CASE is a trademark registered in the United States and many other countries, owned by or licensed to CNH Industrial N.V., its subsidiaries or affiliates. CNH Industrial Capital is a trademark in the United States and many other countries, owned by or licensed to CNH Industrial N.V., its subsidiaries or affiliates. Printed in U.S.A. Contains 10% post-consumer fiber.

IMPORTANT: CASE Construction Equipment Inc. reserves the right to change these specifications without notice and without incurring any obligation relating to such change. Availability of some models and equipment builds vary according to the country in which the equipment is used. The illustrations and text may include optional equipment and accessories and may not include all standard equipment. Your CASE dealer/distributor will be able to give you details of the products and their specifications available in your area.



CASE Construction Equipment is biodiesel-friendly. NOTE: All engines meet current EPA emissions regulations. All specifications are stated in accordance with SAE Standards or Recommended Practices, where applicable.



Always read the Operator's Manual before operating any equipment. Inspect equipment before using it, and be sure it is operating properly. Follow the product safety signs and use any safety features provided.

Form No. CCE202211575NEP

575N EP

6 of 6