



ENGINE

Model	FPT F5H FL463 C*F001
Emissions Certification	Tier 4 Final
Type	4-stroke
Cylinders	4
Bore/Stroke	3.9 x 4.3 in (99 x 110 mm)
Displacement	207 in ³ (3.4 L)
Fuel injection	High pressure, common rail injection
Fuel	Diesel
Fuel filter	Spin on, Beta (4) = 20
Air filter	Dry type element w/ warning restriction indicator
Exhaust aftertreatment:	Particulate Matter Catalyst – PM Catalyst
Radiator:	
Core type	All aluminum
Fan:	
Style	Direct drive
Lubrication/cooling oil pump:	
Style	Integral
Engine oil:	
Pump:	
	Deep sump plate cooler w/ pressurized under-piston nozzles
Pump operating angle ratings:	
Side-to-side	Rated 35°
Fore and aft	Rated 35°
Oil filtration	Spin on, full flow
Engine speeds	RPM
Rated – full load	2500
Low idle	950
High idle – no load	2500
Horsepower @ 2500 RPM:	
Gross	64 hp (48 kW)
Net	60 hp (45 kW)
Peak torque @ 1400 RPM:	
Gross	193 lb-ft (261 N-m)
Net	188 lb-ft (255 N-m)

NOTE: Gross horsepower and torque per SAE J1349.
Net horsepower and torque per SAE J1349.

DRIVETRAIN

Transmission	Hydrostatic transmission	
Pump relief	6,092 psi (42 000 kPa)	
Pump flow @ 2500 RPM	26.4 gpm (100 L/min)	
Differential:	Open standard/limited slip optional	
Front axles:		
Differential ratio	3.67	
Planetary ratio	6.00	
Final axle ratio	22.00	
Gear box:		
1st ratio	1.85	
Planetaries	Outboard	
Service brakes:	Master cylinder hydraulically actuated, caliper on front axle	
Parking brake:	Mechanical, caliper on front axle	
Travel speeds	Forward	Reverse
	mph (kph)	mph (kph)
1st Low	3.1 (5.0)	3.1 (5.0)
2nd High	12.4 (20.0)	12.4 (20.0)

ELECTRICAL

Voltage	12 Volts
Alternator	120 amp
Batteries	95 AHR, 900 CCA

OPERATOR ENVIRONMENT

Base and Deluxe Cab w/ heater; Key start; Articulated power steering w/ tilt column; Full adjustable, cloth suspension seat; Foot throttle; Single joystick w/ electronic speed shift control F/N/R switch and proportional loader control; Cup holder; Retractable seat belt; Storage tray on Deluxe Cab; Sun screen – front; Opening side window; Dome light; Wipers – front and rear; 12-volt auxiliary power; Lighter cigar and ashtray; Pocket cellular phone; Coat hook; External rearview mirrors; Loader control lockout.

Electronic information center

Displays/Gauges:
Vehicle speed; Hourmeter; Floating functionality on; Clock; Vehicle directions; Gear number engaged; PM Catalyst icons.

Indicator lights:
Main hydraulic enabled; Turn light – left and right; Rear work lamps; Work lamps; Main high beam; Side lights; Stop; Warning signal; Rabbit; Hand brake; Brake fluid level; Quick coupler on; Ride Control on; Creep speed; PM Catalyst; Low fuel level; Clogging air filter; Engine oil pressure; Glow plug; Alternator changing.

Audible alarms:
Caution alarm; Critical alarm; Backup alarm.

Horn

NOTE: If equipped w/ option.

OPERATING WEIGHT

XT:	Unit equipped w/ ROPS/FOPS cab w/ heater, standard counterweight, 335/80 R18 Dunlop Tires, front and rear fenders, 1.3 yd ³ (0.8 m ³) general purpose bucket w/ edge, full fuel, 165 lb (75 kg) operator:	11,023 lb (5 000 kg)
Including optional counterweight:		11,354 lb (5 150 kg)
Z-Bar:	Unit equipped w/ ROPS/FOPS cab w/ heater, standard counterweight, 335/80 R18 Dunlop Tires, front and rear fenders, 1.3 yd ³ (0.8 m ³) general purpose bucket w/ edge, full fuel, 165 lb (75 kg) operator:	11,618 lb (5 270 kg)
Including optional counterweight:		11,949 lb (5 420 kg)

HYDRAULICS

Pump – steering/implement:	Open-centered pressure/flow compensated
Fixed gear type:	Max. 17.7 gpm @ 2500 RPM @ 3,626 psi (Max. 67 L/min @ 2500 RPM @ 25 000 kPa)
Loader control valve:	Open-center, Hydraulic Loader Control w/ single lever includes: Forward/Neutral/ Reverse switch, Floating switch, Low/High Travel mode switch, Auxiliary Function Roller
Loader auxiliary steering:	Hydraulic orbital center-pivot articulating w/ on-demand oil flow
Main relief pressure	3,336 psi (23 000 kPa)
Filtration:	15-micron, full flow replaceable cartridges on return line

SERVICE CAPACITIES

Fuel tank	22.7 gal (86.0 L)
Hydraulic system:	
Reservoir	10.6 gal (40.0 L)
Total	14.0 gal (53.0 L)
Front and rear axle:	
Front axle	2.2 gal (8.2 L)
Rear axle	2.5 gal (9.5 L)
Engine oil w/ filter	1.8 gal (7.0 L)
Cooling*	3.4 gal (13.0 L)

NOTE: *1.72 gal (6.5 L) antifreeze + 1.72 gal
(6.5 L) water.

OTHER SPECIFICATIONS

Lift cylinder – XT	One (1)
Bore diameter	4.0 in (101.6 mm)
Rod diameter	2.0 in (50.8 mm)
Stroke	23.6 in (600.0 mm)
Dump cylinder – XT:	
Bore diameter	4.0 in (101.6 mm)
Rod diameter	2.0 in (50.8 mm)
Stroke	15.4 in (391.0 mm)

Lift cylinders – Z-Bar	Two (2)
Bore diameter	2.8 in (70.2 mm)
Rod diameter	2.0 in (50.8 mm)
Stroke	28.7 in (728.0 mm)

Dump cylinder – Z-Bar:	
Bore diameter	3.3 in (82.6 mm)
Rod diameter	1.8 in (44.5 mm)
Stroke	19.4 in (491.5 mm)

Loader:	
XT:	
Parallel loader linkage	
Single control for lift and tilt	
Positive hold float	
Hydraulic attachment coupler:	
Skid steer compatible/horizontal pin compatible	

Z-Bar:	
Z-Bar loader linkage	
Single control for lift and tilt	
Positive hold float	
Hydraulic attachment coupler:	
Skid steer compatible/horizontal pin compatible	

Cycle time:	
XT:	
Raise w/ rated bucket load	4.6 sec
Dump w/ rated bucket load	1.4 sec
Lower – empty	3.8 sec
Z-Bar:	
Raise w/ rated bucket load	6.3 sec
Dump w/ rated bucket load	1.7 sec
Lower – empty	3.8 sec

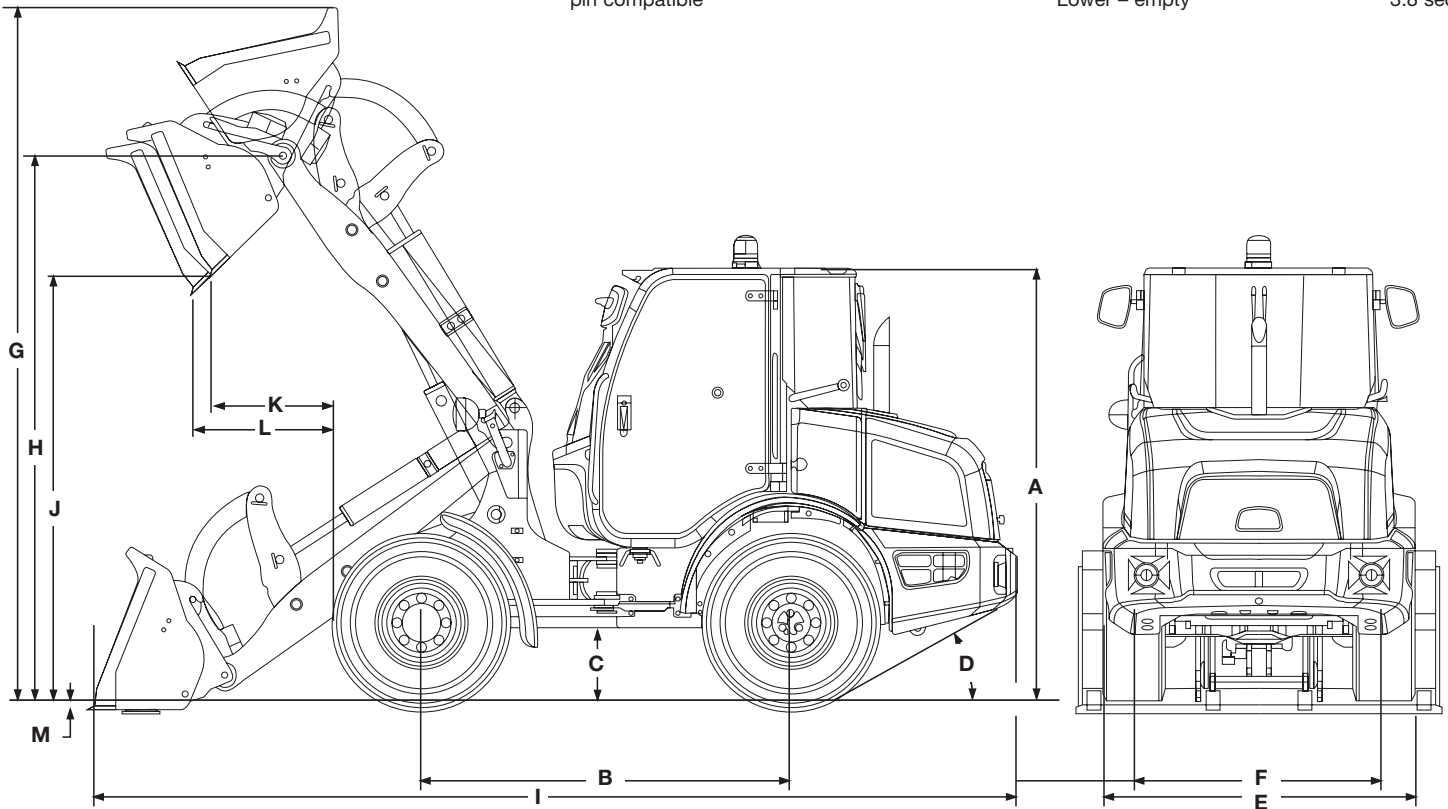

Line drawings are for illustrative purpose only and may not be exact representation of unit.

DIMENSIONS

A. Height to top of ROPS cab	96.7 in (2 457 mm)
B. Wheelbase	81.7 in (2 075 mm)
C. Ground clearance under shaft	17.5 in (444 mm)
Ground clearance under axles	12.6 in (321 mm)
D. Angle of departure	28°
Width:	
E. Overall without bucket	68.5 in (1 740 mm)
F. Centerline tread	55.1 in (1 400 mm)
Turning radius – outside	146.5 in (3 721 mm)
Turning angle:	
From center	40°
Total angle	80°
Rear axle oscillation – total	18°

PERFORMANCE SPECS

121F XT	1.05 yd³ GP (0.8 m³) GP Bucket with Bolt-on Edge	1.44 yd³ GP (1.1 m³) LM Bucket with Bolt-on Edge
ISO bucket capacity – struck	0.78 yd ³ (0.6 m ³)	1.18 yd ³ (0.9 m ³)
Heaped	1.05 yd ³ (0.8 m ³)	1.44 yd ³ (1.1 m ³)
Bucket width – outside	80.7 in (2 050 mm)	82.7 in (2 100 mm)
Bucket weight – includes coupler and added components	946 lb (429 kg)	1,047 lb (475 kg)
G. Operating height – fully raised with spillguard	160.8 in (4 085 mm)	166.1 in (4 218 mm)
H. Hinge pin height – fully raised	123.1 in (3 128 mm)	123.1 in (3 128 mm)
I. Overall length – bucket level on ground	213.6 in (5 426 mm)	217.5 in (5 525 mm)
Dump angle – fully raised	44°	44°
J. Dump height – fully raised, 45° dump	90.2 in (2 292 mm)	87.5 in (2 223 mm)
K. Bucket reach – fully raised, 45° dump	32.4 in (824 mm)	35.2 in (895 mm)
L. Bucket reach – 7 ft 0 in (2.13 m) height, 45° dump	39.6 in (1 005 mm)	39.4 in (1 002 mm)
M. Dig depth	5.6 in (143 mm)	5.6 in (143 mm)
Operating load – ISO	3,542 lb (1 607 kg)	3,499 lb (1 587 kg)
Maximum material density – ISO	3,385 lb/yd ³ (2 008 kg/m ³)	2,432 lb/yd ³ (1 443 kg/m ³)
Tipping load – ISO:		
Straight	8,197 lb (3 718 kg)	8,100 lb (3 674 kg)
Straight with optional counterweight	8,770 lb (3 978 kg)	8,673 lb (3 934 kg)
40° turn	7,083 lb (3 213 kg)	6,997 lb (3 174 kg)
40° turn with optional counterweight	7,586 lb (3 441 kg)	7,500 lb (3 402 kg)
Lift capacity:		
Full height	5,265 lb (2 388 kg)	5,119 lb (2 322 kg)
Maximum reach	5,891 lb (2 672 kg)	5,745 lb (2 606 kg)
Ground	6,237 lb (2 829 kg)	6,010 lb (2 726 kg)
Breakout force with tilt cylinder	6,559 lb (2 975 kg)	5,853 lb (2 655 kg)
Maximum rollback:		
@ Ground	38°	38°
@ Carry position	45°	45°
@ Maximum reach	54°	54°
@ Full height	57°	57°
Maximum grading angle with bucket – back dragging	72°	72°
Loader clearance circle with bucket	343.4 in (8 722 mm)	348.4 in (8 850 mm)

PERFORMANCE SPECS

121F Z-Bar	1.05 yd³ GP (0.8 m³) GP Bucket with Bolt-on Edge	1.44 yd³ GP (1.1 m³) LM Bucket with Bolt-on Edge
ISO bucket capacity – struck	0.78 yd ³ (0.6 m ³)	1.18 yd ³ (0.9 m ³)
Heaped	1.05 yd ³ (0.8 m ³)	1.44 yd ³ (1.1 m ³)
Bucket width – outside	80.7 in (2 050 mm)	82.7 in (2 100 mm)
Bucket weight – includes coupler and added components	1,025 lb (465 kg)	1,127 lb (511 kg)
G. Operating height – fully raised with spillguard	163.5 in (4 154 mm)	169.3 in (4 301 mm)
H. Hinge pin height – fully raised	125.3 in (3 182 mm)	125.3 in (3 182 mm)
I. Overall length – bucket level on ground	222.2 in (5 645 mm)	223.4 in (5 674 mm)
Dump angle – fully raised	47°	47°
J. Dump height – fully raised, 45° dump	92.1 in (2 339 mm)	91.3 in (2 318 mm)
K. Bucket reach – fully raised, 45° dump	39.7 in (1 009 mm)	40.6 in (1 030 mm)
L. Bucket reach – 7 ft 0 in (2.13 m) height, 45° dump	48.1 in (1 222 mm)	48.1 in (1 222 mm)
M. Dig depth	4.4 in (112 mm)	4.4 in (112 mm)
Operating load – ISO	3,449 lb (1 564 kg)	3,586 lb (1 627 kg)
with optional counterweight	3,617 lb (1 641 kg)	3,757 lb (1 704 kg)
Maximum material density – ISO	3,296 lb/yd ³ (1 956 kg/m ³)	2,493 lb/yd ³ (1 479 kg/m ³)
with optional counterweight	3,457 lb/yd ³ (2 051 kg/m ³)	2,611 lb/yd ³ (1 549 kg/m ³)
Tipping load – ISO:		
Straight	8,186 lb (3 713 kg)	8,222 lb (3 729 kg)
Straight with optional counterweight	8,738 lb (3 963 kg)	8,773 lb (3 980 kg)
40° turn	6,898 lb (3 129 kg)	7,173 lb (3 253 kg)
40° turn with optional counterweight	7,234 lb (3 281 kg)	7,513 lb (3 408 kg)
Lift capacity:		
Full height	6,771 lb (3 071 kg)	6,669 lb (3 025 kg)
Full height with optional counterweight	6,779 lb (3 075 kg)	6,677 lb (3 028 kg)
Maximum reach	8,604 lb (3 903 kg)	8,504 lb (3 858 kg)
Ground	10,766 lb (4 883 kg)	10,611 lb (4 813 kg)
Ground with optional counterweight	10,764 lb (4 883 kg)	10,609 lb (4 812 kg)
Breakout force with tilt cylinder	8,971 lb (4 069 kg)	8,590 lb (3 896 kg)
Maximum rollback:		
@ Ground	40°	40°
@ Carry position	47°	47°
@ Maximum reach	58°	58°
@ Full height	61°	61°
Maximum grading angle with bucket – back dragging	59°	60°
Loader clearance circle with bucket	353.2 in (8 972 mm)	355.7 in (9 036 mm)

FORKS

121F XT		With Optional Additional Counterweight
Fork length	47.2 in (1 200 mm)	47.2 in (1 200 mm)
Fork weight – includes coupler	869 lb (394 kg)	869 lb (394 kg)
Operating load – level ground	4,183 lb (1 898 kg)	4,482 lb (2 033 kg)
Tipping load – straight	6,030 lb (2 735 kg)	6,475 lb (2 937 kg)
Tipping load – 40° turn	5,229 lb (2 372 kg)	5,602 lb (2 541 kg)
Fork load center	19.7 in (500 mm)	19.7 in (500 mm)
121F Z-Bar		
Fork length	47.2 in (1 200 mm)	47.2 in (1 200 mm)
Fork weight – includes coupler	869 lb (394 kg)	869 lb (394 kg)
Operating load – level ground	3,917 lb (1 772 kg)	4,195 lb (1 903 kg)
Tipping load – straight	5,670 lb (2 572 kg)	6,067 lb (2 752 kg)
Tipping load – 40° turn	4,896 lb (2 221 kg)	5,244 lb (2 378 kg)
Fork load center	19.7 in (500 mm)	19.7 in (500 mm)

STANDARD EQUIPMENT

OPERATOR ENVIRONMENT

See page 1

ENGINE

FPT F5H FL463 C*F001
Fuel filter with water trap
Dual element air cleaner

LOADER

See page 2

DRIVETRAIN

4-wheel drive
Open – front and rear axles
Hydrostatic transmission
Single joystick with electronic speed shift control F/N/R switch and proportional loader control
Outboard planetary axles
Dry disc brakes
Mechanical parking brake

HYDRAULICS

Hydraulic remote control
3-spool loader control valve
3 Diagnostic quick couplers

OTHER

Front and rear fenders
Lights:
2 Front driving headlights – high/low beam
2 Rear flood lights
2 Stop tail lights and backup light
Front and rear turn signal/flash
Drawbar pin
Articulation locking pin
Tie-down and Lift-up point – front and rear
Backup alarm
Wired for radio
Bucket position indicator

OPTIONAL EQUIPMENT

OPERATOR ENVIRONMENT

Creep speed 0 – 3.1 mph (5 kph)
TeleScop adjustable steering column on Deluxe Cab
Rotating beacon
Limited slip – front and rear axles
Mechanical coupler
Horizontal pin coupler
Air conditioning
Radio ready antenna and speakers

LOADER

Additional auxiliary flow:
Max. 17.7 gpm @ 2500 RPM @ 3,626 psi
(Max. 67 L/min @ 2500 RPM @ 25 000 kPa)
Buckets – see performance data:
General purpose standard
General purpose light material
4-IN-1®
STD forks
Tilttable forks
Auto Ride Control
Return to dig

TIRES

12.5-18 1PRMPT-04TBL MITAS
335/80 R18 EM MITAS
335/80 R18 SPT9 L2 DUNL – Standard
365/70 R18 EM MITAS
365/70 R18 SPT9 L2 DUNL

OTHER

Tool box
Counterweight:
330 lb (150 kg)
Mounts on rear chassis

CaseCE.com

©2016 CNH Industrial America LLC. All rights reserved. CASE is a trademark registered in the United States and many other countries, owned by or licensed to CNH Industrial N.V., its subsidiaries or affiliates. CNH Industrial Capital is a trademark in the United States and many other countries, owned by or licensed to CNH Industrial N.V., its subsidiaries or affiliates. Printed in U.S.A. Contains 10% post-consumer fiber.

IMPORTANT: CASE Construction Equipment Inc. reserves the right to change these specifications without notice and without incurring any obligation relating to such change. Availability of some models and equipment builds vary according to the country in which the equipment is used. The illustrations and text may include optional equipment and accessories and may not include all standard equipment. Your CASE dealer/distributor will be able to give you details of the products and their specifications available in your area.



CASE Construction Equipment is biodiesel-friendly. NOTE: All engines meet current EPA emissions regulations. All specifications are stated in accordance with SAE Standards or Recommended Practices, where applicable.



Always read the Operator's Manual before operating any equipment. Inspect equipment before using it, and be sure it is operating properly. Follow the product safety signs and use any safety features provided.

Form No. CCE201603121F
Replaces Form No. CCE201504121F